

INSTALLATION



IS90-PW Wall Mount



Indoor Only

C2234M (2/07)

Important Safety Instructions

1. Read these instructions.
2. Keep these instructions.
3. Heed all warnings.
4. Follow all instructions.
5. Only use attachments/accessories specified by the manufacturer.
6. Installation should be done only by qualified personnel and conform to all local codes.
7. Use only installation methods and materials capable of supporting four times the maximum specified load.
8. Unless the unit is specifically marked as a NEMA Type 3, 3R, 3S, 4, 4X, 6, or 6P enclosure, it is designed for indoor use only and it must not be installed where exposed to rain and moisture.
9. Use only replacement parts recommended by Pelco.

Description

The IS90-PW pendant wall mount is specifically designed for the IS90 Camclosure® series. The mount offers full feedthrough connections for a clean installation with no exposed wires.

The following parts are supplied:

- 1 Adapter plate with locking screw
- 1 Wall mount
- 2 8-32 x 0.75-inch screws

MODELS

| | |
|----------|----------------------------|
| IS90-PW | Indoor white pendant mount |
| IS90B-PW | Indoor black pendant mount |

Installation

To install the IS90-PW/IS90B-PW pendant wall mount, complete the following steps:

1. Run 24 VAC power, video (coaxial or UTP), and camera control wiring to the mounting location. If you are using coaxial video, do not attach a BNC connector to the cable until step 5.
2. Thread the 24 VAC power, video (coaxial or UTP), and control wiring through the large access hole in the adapter plate. Then attach the adapter plate to the mounting surface using either the top/bottom or left/right pair of mounting holes. (The top/bottom pair is shown in Figure 1.)

NOTE: If mounting to anything other than a junction box, select appropriate mounting hardware for the mounting surface

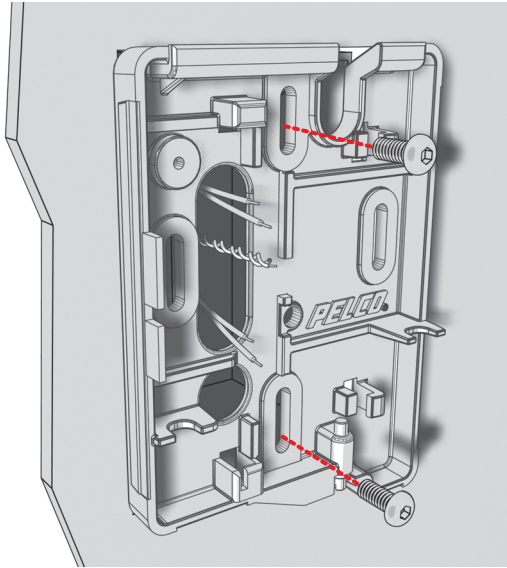

Figure 1. Mounting the Adapter Plate

3. Thread the wiring through the wall mount, and then attach the mount to the adapter plate:
 - a. Locate the mount hooks in the mount. Hang these hooks onto the adapter plate guides.
 - b. Make sure all wires are enclosed in the mount.
 - c. Rock the mount into place.

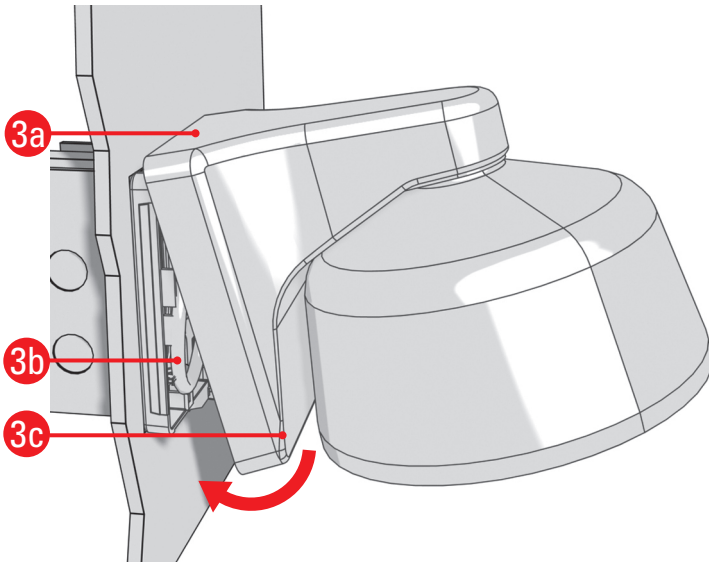

Figure 2. Attaching the Mount

4. Lock the mount:
 - a. Locate the slide lock at the base of the mount. Slide it to the right to secure the mount.
 - b. Turn the locking screw counterclockwise until the slide lock is secured.

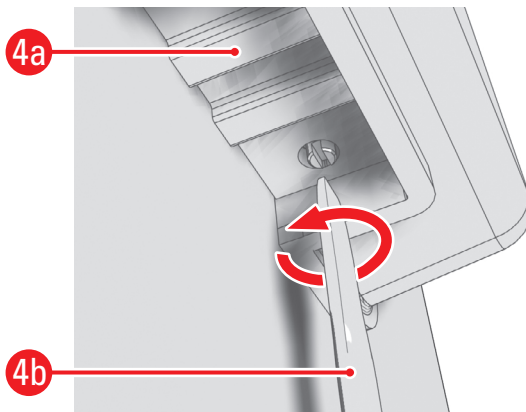

Figure 3. Locking the Mount

5. Connect the video cable/wires to the IS90 back box:

BNC: Connect the BNC connector from the unit to a mating BNC connector.

Twisted Pair (UTP): Blue wire = Video +
Gray wire = Video –

6. Connect the power wires.

| Voltage | Red Wire | Black Wire |
|---------|----------|------------|
| 12 VDC | + | Ground |
| 24 VAC | ~ | ~ |

7. Use the provided mounting screws and attach the back box to the mount.
8. To position and adjust the camera, and to install the liner and bubble, refer to the Installation and Operation manual supplied with the IS90 Camclosure integrated camera system.

Specifications

MECHANICAL

Mounting Method Attach the mount to a wall.

GENERAL

Construction

Mount ABS plastic

Adapter Plate Aluminum

Finish

IS90-PW White

IS90B-PW Black

Unit Weight 0.24 lb (0.11 kg)

Shipping Weight 1.00 lb (0.45 kg)

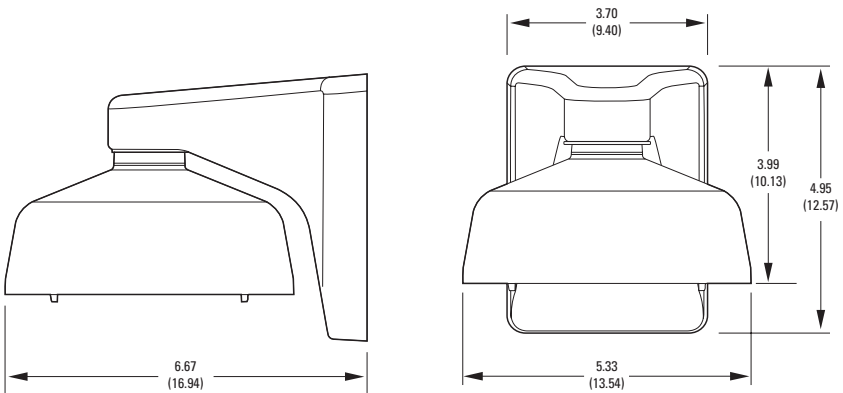

NOTE: VALUES IN PARENTHESES ARE CENTIMETERS; ALL OTHERS ARE INCHES

PRODUCT WARRANTY AND RETURN INFORMATION

WARRANTY

Pelco will repair or replace, without charge, any merchandise proved defective in material or workmanship **for a period of one year** after the date of shipment.

Exceptions to this warranty are as noted below:

- Five years on FR/FT/FS Series fiber optic products and TW3000 Series unshielded twisted pair transmission products.
- Three years on Spectra® IV products.
- Three years on Genex® Series products (multiplexers, server, and keyboard).
- Three years on Camclosure® and fixed camera models, except the CC3701H-2, CC3701H-2X, CC3751H-2, CC3651H-2X, MC3651H-2, and MC3651H-2X camera models, which have a five-year warranty.
- Three years on PMCL200/300/400 Series LCD monitors.
- Two years on standard motorized or fixed focal length lenses.
- Two years on Legacy®, CM6700/CM6800/CM9700 Series matrix, and DF5/DF8 Series fixed dome products.
- Two years on Spectra III™, Esprit®, ExSite™, and PS20 scanners, including when used in continuous motion applications.
- Two years on Esprit and WW5700 Series window wiper (excluding wiper blades).
- Two years (except lamp and color wheel) on Digital Light Processing (DLP®) displays. The lamp and color wheel will be covered for a period of 90 days. The air filter is not covered under warranty.
- Eighteen months on DX Series digital video recorders, NVR300 Series network video recorders, and Endura™ Series distributed network-based video products.
- One year (except video heads) on video cassette recorders (VCRs). Video heads will be covered for a period of six months.
- Six months on all pan and tilts, scanners or preset lenses used in continuous motion applications (that is, preset scan, tour and auto scan modes).

Pelco will warrant all replacement parts and repairs for 90 days from the date of Pelco shipment. All goods requiring warranty repair shall be sent freight prepaid to Pelco, Clovis, California. Repairs made necessary by reason of misuse, alteration, normal wear, or accident are not covered under this warranty.

Pelco assumes no risk and shall be subject to no liability for damages or loss resulting from the specific use or application made of the Products. Pelco's liability for any claim, whether based on breach of contract, negligence, infringement of any rights of any party or product liability, relating to the Products shall not exceed the price paid by the Dealer to Pelco for such Products. In no event will Pelco be liable for any special, incidental or consequential damages (including loss of use, loss of profit and claims of third parties) however caused, whether by the negligence of Pelco or otherwise.

The above warranty provides the Dealer with specific legal rights. The Dealer may also have additional rights, which are subject to variation from state to state.

If a warranty repair is required, the Dealer must contact Pelco at (800) 289-9100 or (559) 292-1981 to obtain a Repair Authorization number (RA), and provide the following information:

1. Model and serial number
2. Date of shipment, P.O. number, Sales Order number, or Pelco invoice number
3. Details of the defect or problem

If there is a dispute regarding the warranty of a product which does not fall under the warranty conditions stated above, please include a written explanation with the product when returned.

Method of return shipment shall be the same or equal to the method by which the item was received by Pelco.

RETURNS

In order to expedite parts returned to the factory for repair or credit, please call the factory at (800) 289-9100 or (559) 292-1981 to obtain an authorization number (CA number if returned for credit, and RA number if returned for repair).

All merchandise returned for credit may be subject to a 20% restocking and refurbishing charge.

Goods returned for repair or credit should be clearly identified with the assigned CA or RA number and freight should be prepaid. Ship to the appropriate address below.

If you are located within the continental U.S., Alaska, Hawaii or Puerto Rico, send goods to:

Service Department
Pelco
3500 Pelco Way
Clovis, CA 93612-5699

If you are located outside the continental U.S., Alaska, Hawaii or Puerto Rico and are instructed to return goods to the USA, you may do one of the following:

If the goods are to be sent by a COURIER SERVICE, send the goods to:

Pelco
3500 Pelco Way
Clovis, CA 93612-5699 USA

If the goods are to be sent by a FREIGHT FORWARDER, send the goods to:

Pelco c/o Expeditors
473 Eccles Avenue
South San Francisco, CA 94080 USA
Phone: 650-737-1700
Fax: 650-737-0933

 Green The materials used in the manufacture of this document and its components are compliant to the requirements of Directive 2002/95/EC.

REVISION HISTORY

| Manual # | Date | Comments |
|----------|------|-------------------|
| C2234M | 2/07 | Original version. |

Pelco, the Pelco logo, Camclosure, Esprit, Genex, Legacy, and Spectra are registered trademarks of Pelco.
Endura and ExSite are trademarks of Pelco.
DLP is a registered trademark of Texas Instruments, Inc.

©Copyright 2007, Pelco.
All rights reserved.



Worldwide Headquarters
3500 Pelco Way
Clovis, California 93612 USA

USA & Canada
Tel: 800/289-9100
Fax: 800/289-9150
International
Tel: 1-559/292-1981
Fax: 1-559/348-1120

www.pelco.com

ISO9001

Australia | Canada | Finland | France | Germany | Italy | Macau | The Netherlands | Russia | Singapore
South Africa | Spain | Sweden | United Arab Emirates | United Kingdom | United States